

82L...-4... SERIES

Pneumatic Power Clamps | Ordering Information

82L **16-4** **03** **0**

Base Model	Size	Description	Arm Style	Description	Opening Angle	Description
	12-4	12mm Cylinder Bore Size	00	No clamping arm	0	105° (Standard)
	16-4	16mm Cylinder Bore Size	03	U-bar, central 90°	3	90°
	20-4	20mm Cylinder Bore Size	43	U-bar, central 180°	4	75°
	25-4	25mm Cylinder Bore Size	See below for further details		5	60°
					6	45°
					7	30°
					8	15°

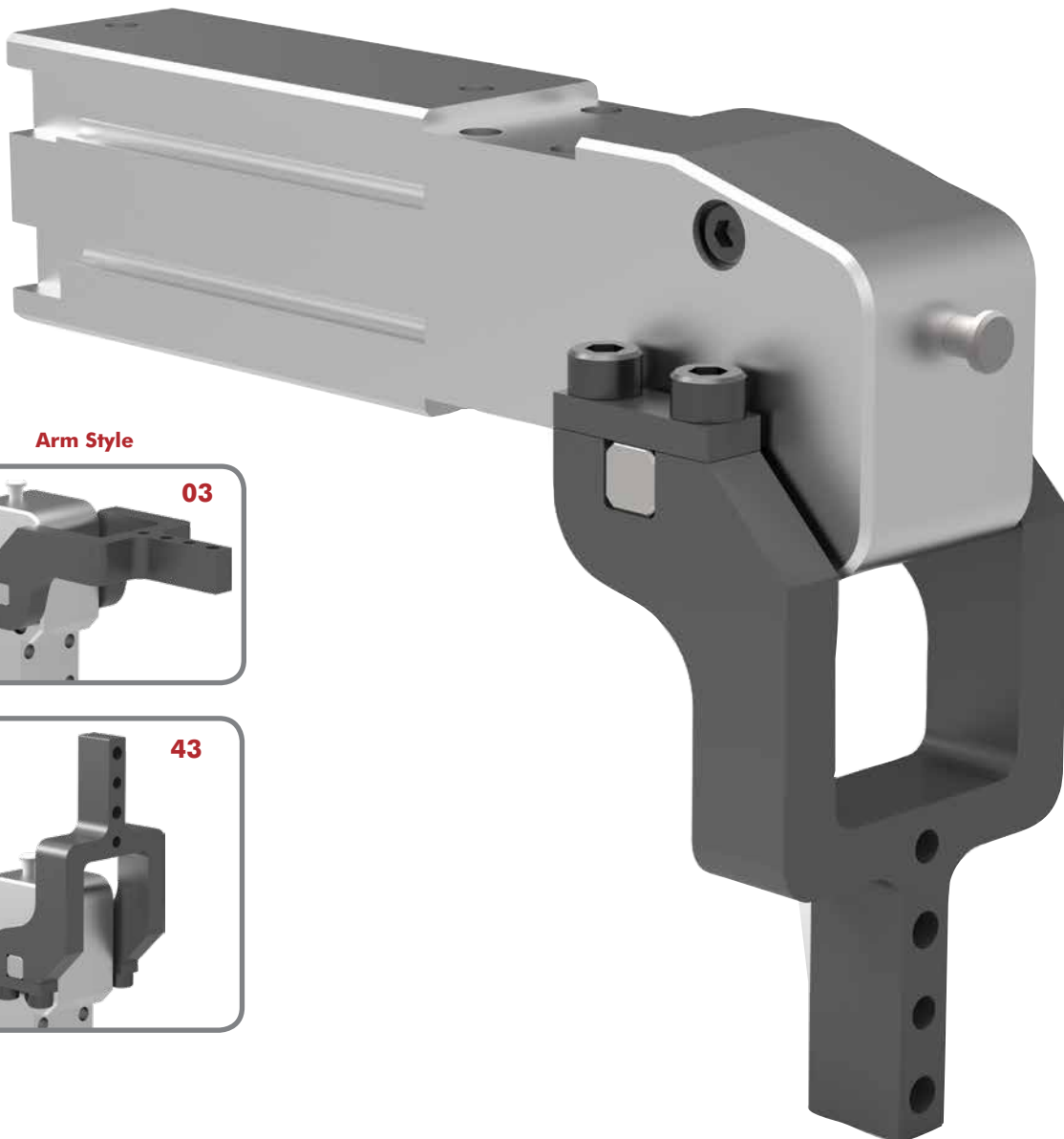

Arm Style

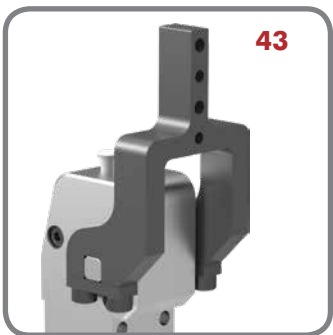
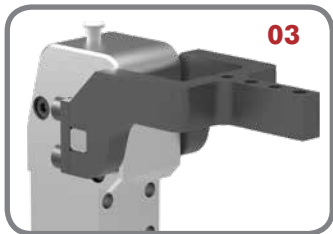

82L..-4... SERIES

Pneumatic Power Clamps | Ordering Information

Accessories

8EA-109-1

82ZB-004-1

Description (order separately)

Sensor, 3-wire cable, M8x1 connector, 3-pin

Adapter for mounting 82L20-4, 82L25-4 to 25mm dia. bar

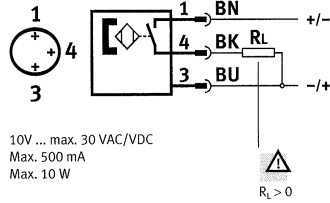

12

Max Holding Torque
35 Nm

Max Clamping Torque

90° version: 10,4 Nm at 5bar

180° version: 8,7 Nm at 5bar

16

Max Holding Torque
40 Nm

Max Clamping Torque

12,4 Nm at 5bar

11,0 Nm at 5bar

20

Max Holding Torque
50 Nm

Max Clamping Torque

21,0 Nm at 5bar

19,3 Nm at 5bar

25

Max Holding Torque
80 Nm

Max Clamping Torque

31,8 Nm at 5bar

28,5 Nm at 5bar

82L12-4 SERIES

Pneumatic Power Clamps | Dimensions | Technical Specifications

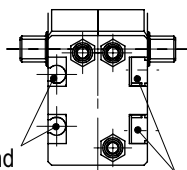
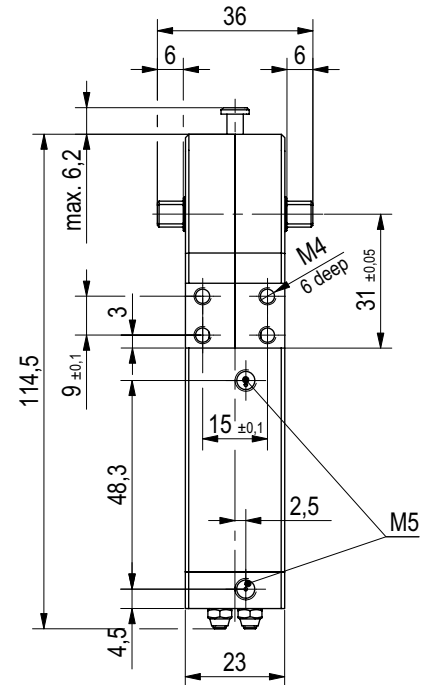
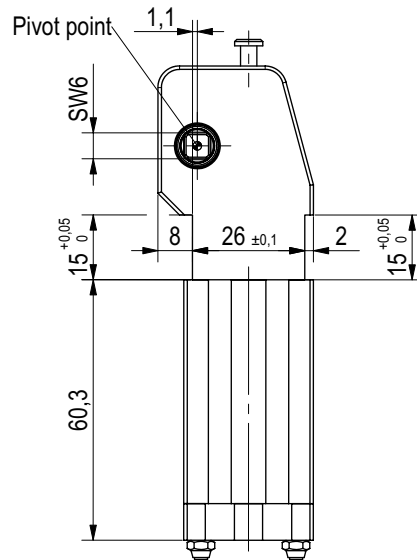
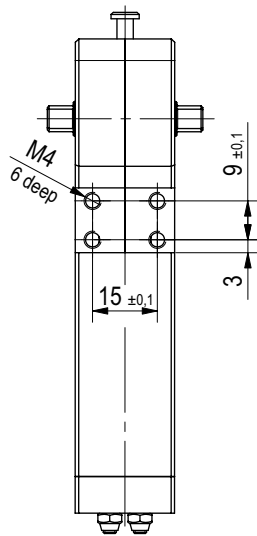
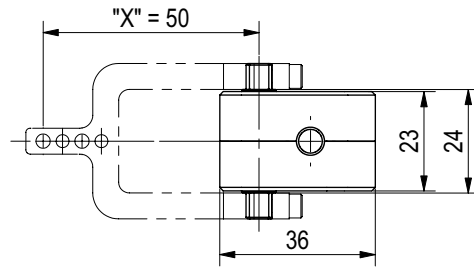

Slot for round sensor

T-slot for sensor

mm [INCH]

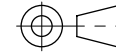

THIRD ANGLE PROJECTION

Power by compressed air, max. 6 bar Operation with oil-free air is permissible.

Model	Max. Holding Torque Nm [lb ft]	Max. Clamping Torque at 5 bar [72 psi] Nm [lb ft]	Weight [with arm] kg [lb]	Air Consumption per double stroke at 5 bar [72 psi] dm ³ [ft ³]	Max. Added Load (at Position "X") g [oz]
82L12-4030	35 [25.8]	10,4 [7.8]	0,23 [0.5]	0,25 [0.01]	50 [1.8]
82L12-4430	35 [25.8]	8,7 [6.4]	0,23 [0.5]	0,25 [0.01]	50 [1.8]

82L16-4 SERIES

Pneumatic Power Clamps | Dimensions | Technical Specifications

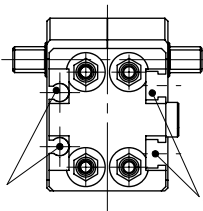
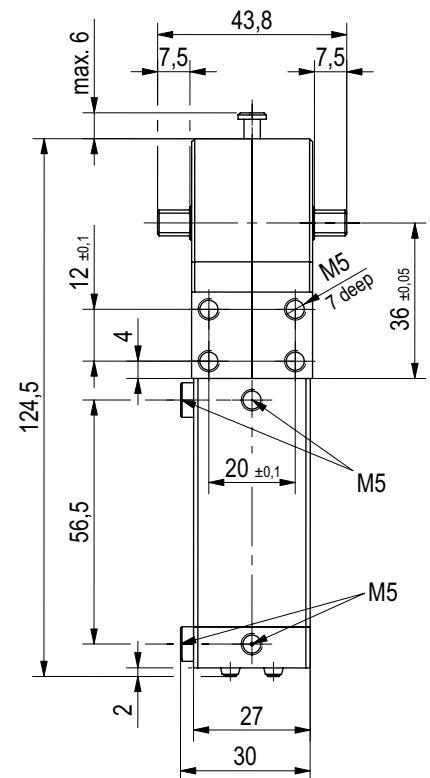
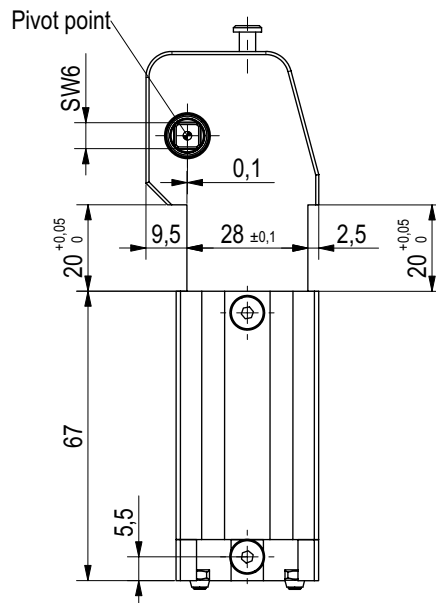
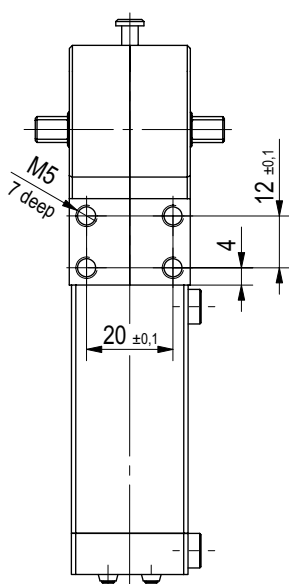
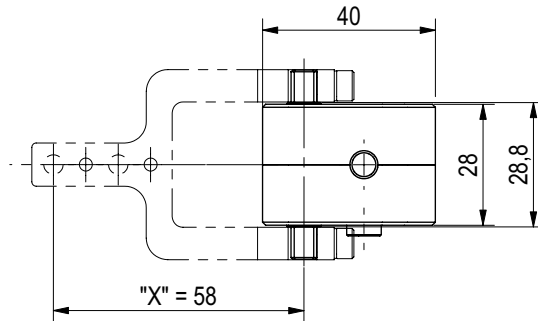

Slot for round sensor

T-slot for sensor

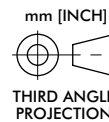

Power by compressed air, max. 6 bar Operation with oil-free air is permissible.

Model	Max. Holding Torque Nm [lb ft]	Max. Clamping Torque at 5 bar [72 psi] Nm [lb ft]	Weight [with arm] kg [lb]	Air Consumption per double stroke at 5 bar [72 psi] dm ³ [ft ³]	Max. Added Load (at Position "X") g [oz]
82L16-4030	40 [29.5]	12,4 [9.4]	0,33 [0.7]	0,27 [0.01]	80 [2.8]
82L16-4430	40 [29.5]	11,0 [8.1]	0,33 [0.7]	0,27 [0.01]	80 [2.8]

82L20-4 SERIES

Pneumatic Power Clamps | Dimensions | Technical Specifications

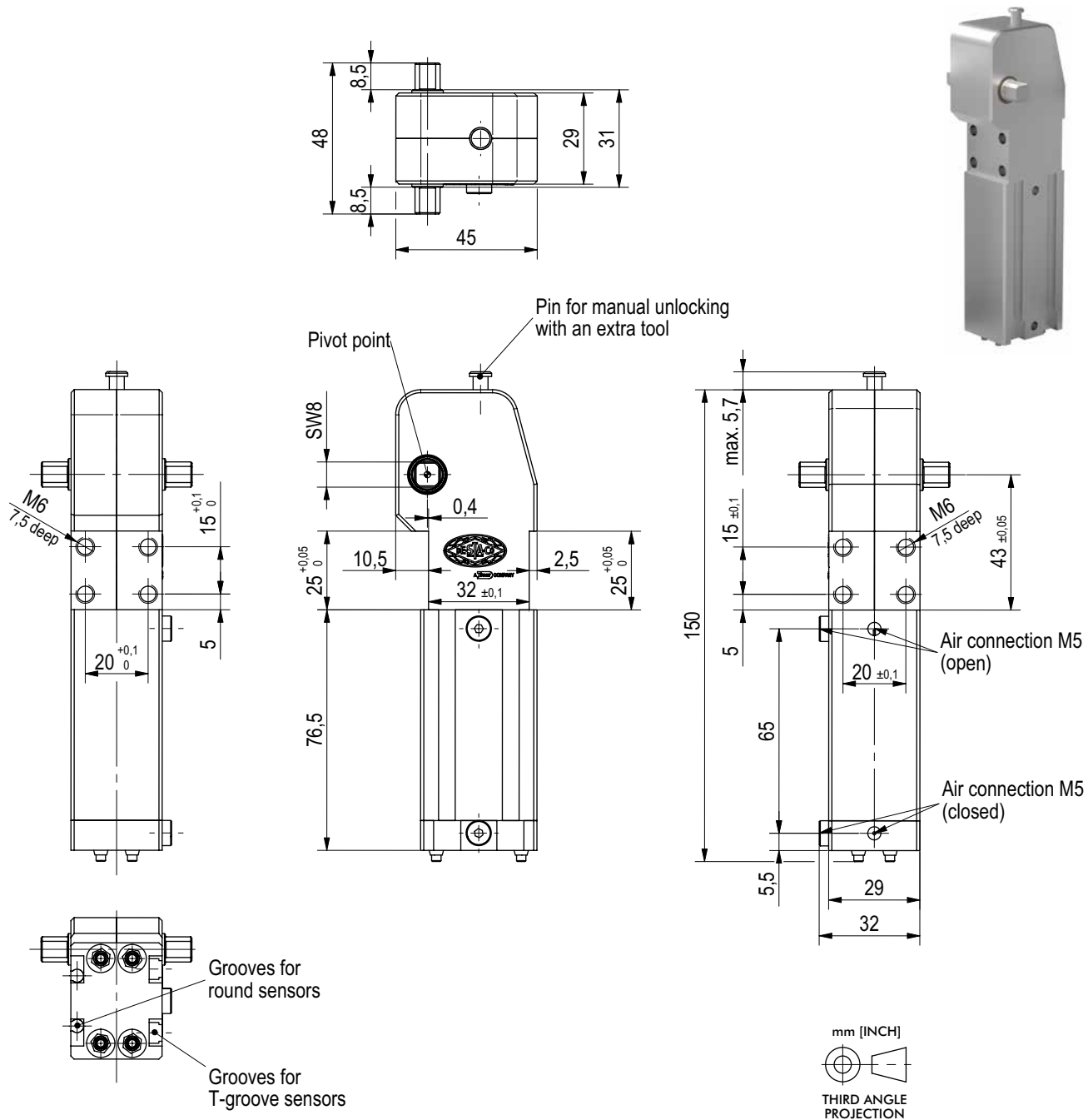

Power by compressed air, max. 6 bar Operation with oil-free air is permissible.

Model	Max. Holding Torque Nm [lb ft]	Max. Clamping Torque at 5 bar [72 psi] Nm [lb ft]	Weight [with arm] kg [lb]	Air Consumption per double stroke at 5 bar [72 psi] dm ³ [ft ³]	Max. Added Load (at Position "X") g [oz]
82L20-4030	50 [36.9]	21,0 [15.5]	0,42 [0.9]	0,35 [0.01]	90 [3.2]
82L20-4430	50 [36.9]	19,3 [14.3]	0,42 [0.9]	0,35 [0.01]	90 [3.2]

82L25-4 SERIES

Pneumatic Power Clamps | Dimensions | Technical Specifications

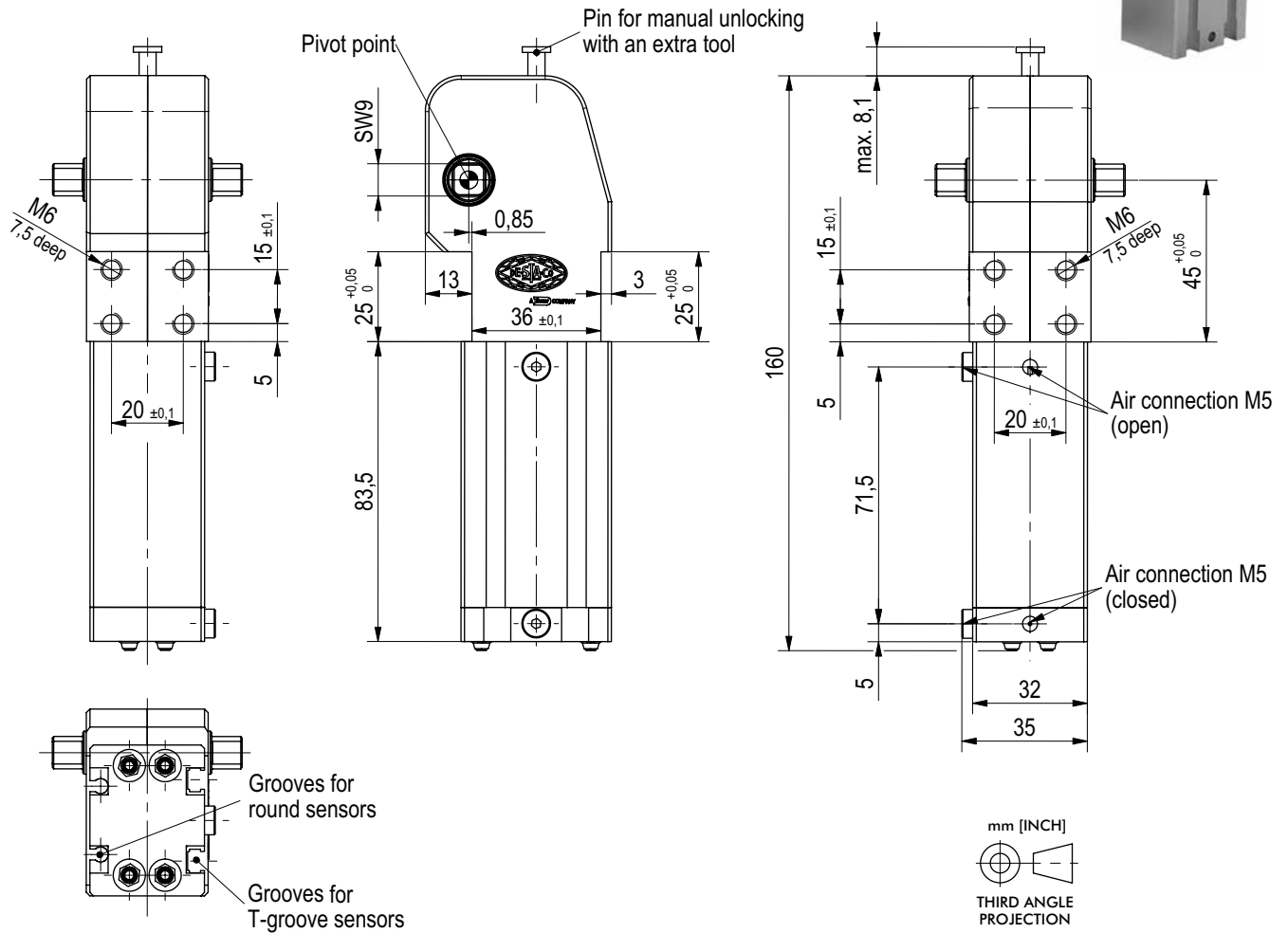
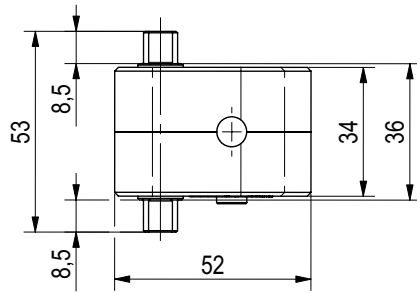

Power by compressed air, max. 6 bar Operation with oil-free air is permissible.

Model	Max. Holding Torque Nm [lb ft]	Max. Clamping Torque at 5 bar [72 psi] Nm [lb ft]	Weight [with arm] kg [lb]	Air Consumption per double stroke at 5 bar [72 psi] dm ³ [ft ³]	Max. Added Load (at Position "X") g [oz]
82L25-4030	80 [59]	31,8 [23.5]	0,66 [1.5]	0,40 [0.01]	100 [3.5]
82L25-4430	80 [59]	28,5 [12.5]	0,66 [1.5]	0,40 [0.01]	100 [3.5]

82L...-4... SERIES

Pneumatic Power Clamps | Clamp Arm Dimensions

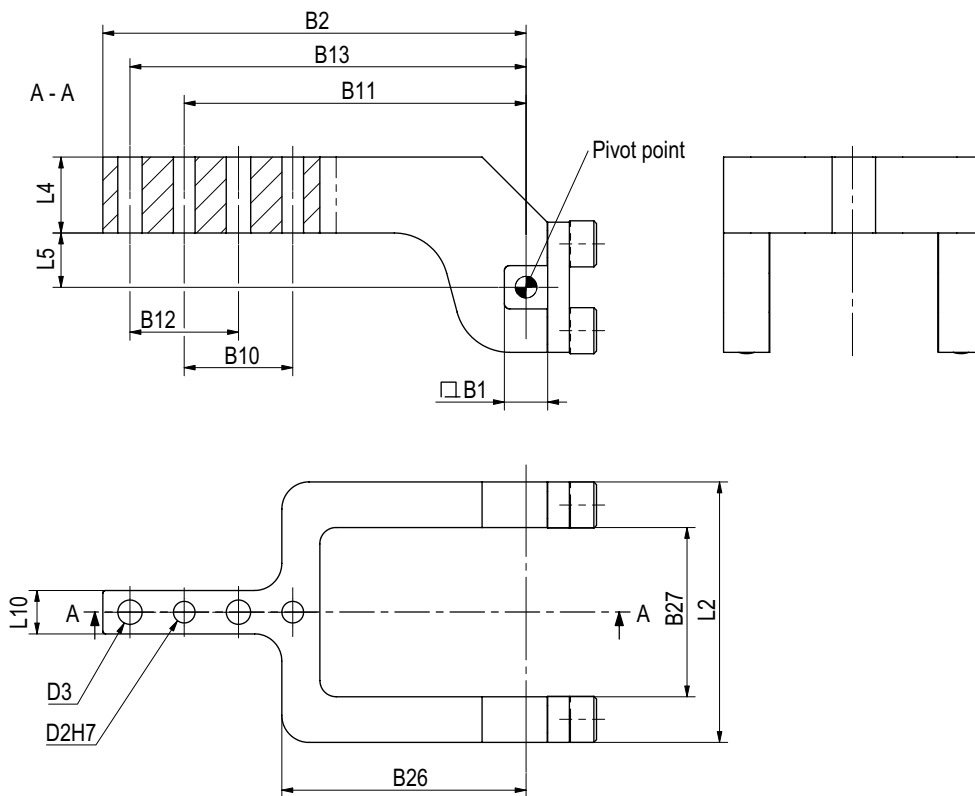

Model	Order no. for Arm	Max. Opening angle	B1	B2	B10 ±0,02	B11 ±0,02	B12 ±0,1	B13 ±0,1	B26	B27	D2 H7	D3	L2	L4	L5	L10
82L12-4...	8JG-401-1-01	105°	6	54	9	45.5	9	50	38,5	24	3	3.3	36	7	10	6
82L16-4...	8JG-402-1-01	105°	6	63	15	50.5	15	58	36,5	29	3	4.5	44	9.5	10	10
82L20-4...	8JG-403-1-01	105°	8	78	20	63	20	73	45	31,2	4	4.5	48	14	10	8
82L25-4...	8JG-404-1-01	105°	9	81	20	66	20	76	48	36	4	6.4	53	16	10	12

